



SPECIFICATION



High Quality Since 1954



CARATTERISTICHE



CHASSIS

CHASSIS

Heavy duty, all welded box type section frame.

OUTRIGGERS

4 independent hydraulically operated telescopic outrigger beams with vertical hydraulic jacks and lock valves. Removable floats. Electro-hydraulic controls with partial extension facility controlled from cab.

ENGINE

CATERPILLAR ACERT C6.6, six cylinders turbocharged intercooler diesel engine, electronically controlled and water cooled. Max power 116.5kW at 2.200 rpm. Max torque 683 Nm at 1.400 rpm. Dry type air cleaner with safety cartridge and service indicator. Fuel tank capacity 240 l.

TRANSMISSION

Engine mounted torque converter driving an electro-hydraulically controlled powershift transmission having 6 forward and 6 reverse speeds.

HYDRAULIC PUMPS

5 gear type hydraulic pump system, driven from power-take-offs mounted on torque converter and engine. Total pumps capacity 380 l/min. Oil tank capacity 430 l.

AXLES

Front: driving/steering axle with differential and planetary reduction solidly mounted to frame.

Rear: driving/steering axle with differential and planetary reduction, pivot mounted. Automatic rear axle oscillation lockout.

STEERING

Front: hydraulically powered steering controlled by steering wheel. Rear: independent hydraulically powered steering with rear wheel alignment indicator. Four steering modes: only front, only rear, coordinated and crab steering. Positive lock to hold in center line rear wheels for road travel.

BRAKES

Service and emergency: compressed air over hydraulic pressure dual independent braking system, foot operated on all wheels. Parking: disk type, spring set, air released brake actuator acting on front axle.

TYRES

16.00 x 25 - earthmover type, single mounted front and rear.

ELECTRICAL EQUIPMENT

24 V starting and lighting equipment according to EC traffic regulations.

SUPERSTRUCTURE

SUPERSTRUCTURE FRAME

Fabricated from high tensile steel plate.

BOOM

4 sections 9.1 to 29.5 m automatically synchronized fully powered telescopic boom. Max. boom head height 32.3 m.

BOOM ELEVATION

Single double-acting hydraulic cylinder. Elevation from -3° a +82°.

SLEW

360° continuous rotation. Piston type hydraulic motor driving slewing pinion through planetary double reduction unit. Spring applied, hydraulically released multidisc type slew brake. Free swing device. External gear teeth slew ring. Hand operated positive slew lock controlled from operator's cab.

MAIN HOIST

Hydraulic, two speeds. Twin piston type hydraulic motor driving grooved hoist drum through double reduction gear unit.

Spring applied, hydraulically released fail-safe hoist brake and counterbalance valve.

OPERATOR'S CAB

Turntable mounted on rubber grommets, left hand drive, fully enclosed, all steel construction with safety glass and operator's seat on slides with height and rake adjustment.

CRANE CONTROLS

Armrest mounted joysticks for independent or simultaneous operation of crane motions; electric switches for control of outriggers, fast hoist speed and free swing.

CONTROL VALVES

Individual valve banks permitting simultaneous independent control of multiple crane functions.

Centralized system for hydraulic pressure control.

TRAVEL CONTROLS

Adjustable steering wheel for control of front steering axle.

Electric switch for independent steering of rear axle. Transmission gear selection, forward-reverse shift and parking brake control.

Control switch for high-low range speeds with automatic 2 or 4 wheel drive selection. Master gauge for engine diagnostic.

SAFETY DEVICES

Overhoist and overload limit switches; lock valves on all cylinders; hydraulic overload valves on all systems.

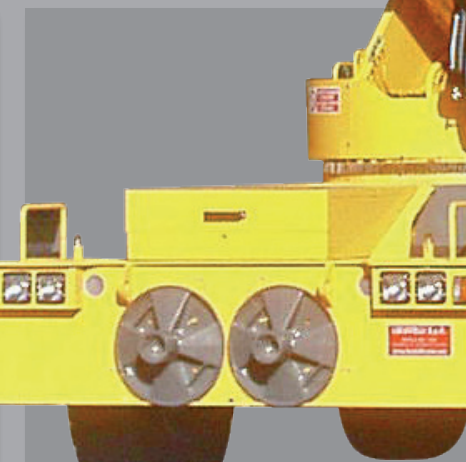
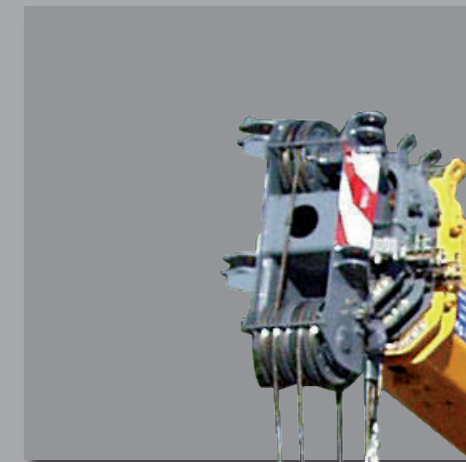

OPTIONAL EQUIPMENT

- 8.0 m offsetable lattice extension
- 9.0 - 16.1 telescopic offsetable extension
- Single hook 5.000 kg capacity
- Hookblock 12.000 kg
- Auxiliary hoist, max line pull 4.000 kg
- Work lights (on cab and base boom)

- Motion cut equipment*
- Electronic safe load indicator*
- Independent cab heater/defroster*
- Air conditioned
- Spare tyre 16.00 x 25

*Standard equipment for CE machine

R1:
4 ruote sterzate
4 wheels steered

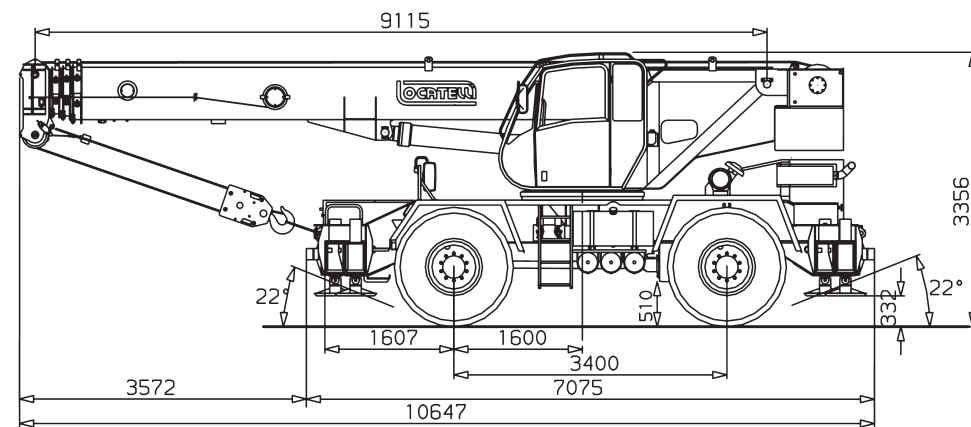

Dimensioni (mm)

Sede Amministrativa e Produttiva
Via Lombardia 32
24030, Mapello (BG) - Italy

Tel. +39 035 4945066
Fax +39 035 4945549

Sede Commerciale e Assistenza
Via dell'Industria 2 bis
30031, Dolo (VE) - Italy

Tel. +39 041 410767
Fax +39 041 412048

Sede Legale e Domicilio Fiscale
Via dell'Industria 7
30031, Dolo (VE) - Italy

www.locatelllicrane.com

GRIL 8400 T

ACCESSORI A RICHIESTA

- Prolunga a traliccio inclinabile da 8 m
- Prolunga telescopica inclinabile da 9.0 a 16.1 m
- Gancio a pala 5.000 kg
- Bozzello ad 1 camucola da 12.000 kg
- Argano ausiliario tiro 4.000 kg
- Faro di lavoro (cabina e sezione base del braccio)

- Indicatore elettronico di carico*
- Dispositivo taglio movimenti*
- Riscaldamento indipendente cabina *
- Aria condizionata
- Ruota di scorta 16.00x25

* Accessori standard secondo le normative CE

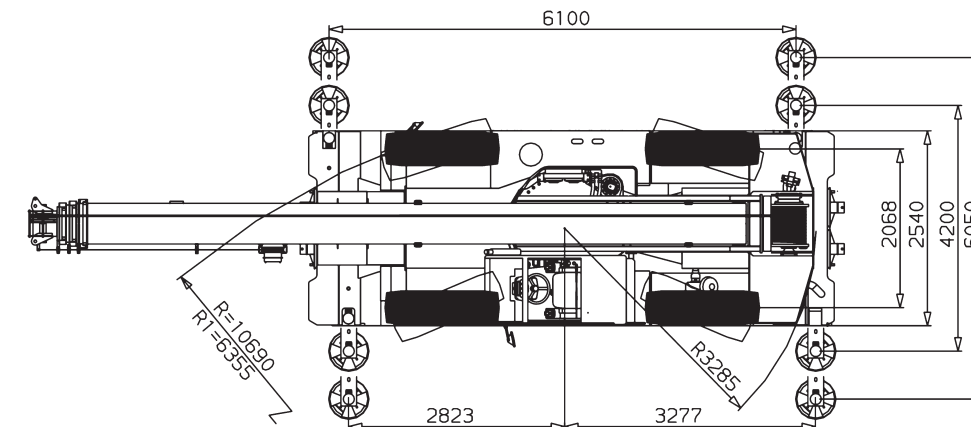

Dimensioni (mm)

PORTATE BRACCIO TELESCOPICO - LIFTING CAPACITIES TELESCOPIC BOOM - CAPACITES DE LEVAGE FLECHE TELESCOPIQUE - TRAGLASTEN TELESKOPUSLEGER - CAPACIDADES DE CARGA PLUMA TELESCOPICA



m	0 km/h						m
	9,1 m	14,2 m	19,3 m	24,4 m	28,5 m	29,5 m	
3,0	35,0	19,1	17,1				3,0
3,5	32,7	19,5	17,5				3,5
4,0	30,4	19,9	17,5	13,0			4,0
4,5	27,6	20,4	17,5	13,0	8,9		4,5
5,0	24,7	19,0	17,0	13,0	9,0	8,0	5,0
6,0	20,2	18,2	16,0	12,0	9,0	8,0	6,0
7,0		15,8	15,9	11,5	9,0	8,0	7,0
8,0		13,0	12,9	10,5	8,5	8,0	8,0
9,0		10,9	10,9	9,5	7,8	7,7	9,0
10,0		8,8	8,8	8,6	7,0	7,0	10,0
12,0		6,4	6,4	6,4	5,8	5,7	12,0
14,0			5,1	5,1	4,8	4,7	14,0
16,0				3,8	3,8	3,8	16,0
18,0					3,1	3,1	18,0
20,0					2,5	2,5	20,0
22,0					1,7	1,8	22,0
24,0						1,6	24,0
26,0						1,3	26,0
27,0						1,2	27,0



m	0 km/h						m
	360°						
	9,1 m	14,2 m	19,3 m	9,1 m	14,2 m	19,3 m	
3,0	14,8	15,1	15,2	18,4	18,4	17,1	3,0
3,5	11,4	11,6	11,8	15,0	15,0	15,0	3,5
4,0	9,1	9,4	9,5	12,5	12,8	12,9	4,0
4,5	7,5	7,7	7,9	10,4	10,7	10,8	4,5
5,0	6,3	6,5	6,6	8,8	9,1	9,2	5,0
6,0		5,0	5,1	6,8	7,1	7,2	6,0
7,0		3,9	4,0		5,6	5,7	7,0
8,0		3,0	3,1		4,5	4,6	8,0
9,0		2,4	2,5		3,7	3,8	9,0
10,0		1,9	2,0		3,1	3,2	10,0
12,0						2,3	12,0
14,0						1,6	14,0
15,0						1,4	15,0

DIAGRAMMA DI LAVORO - WORKING DIAGRAM - DIAGRAMME DE TRAVAIL - ARBEITSBEREICH - DIAGRAMA DE TRABAJO

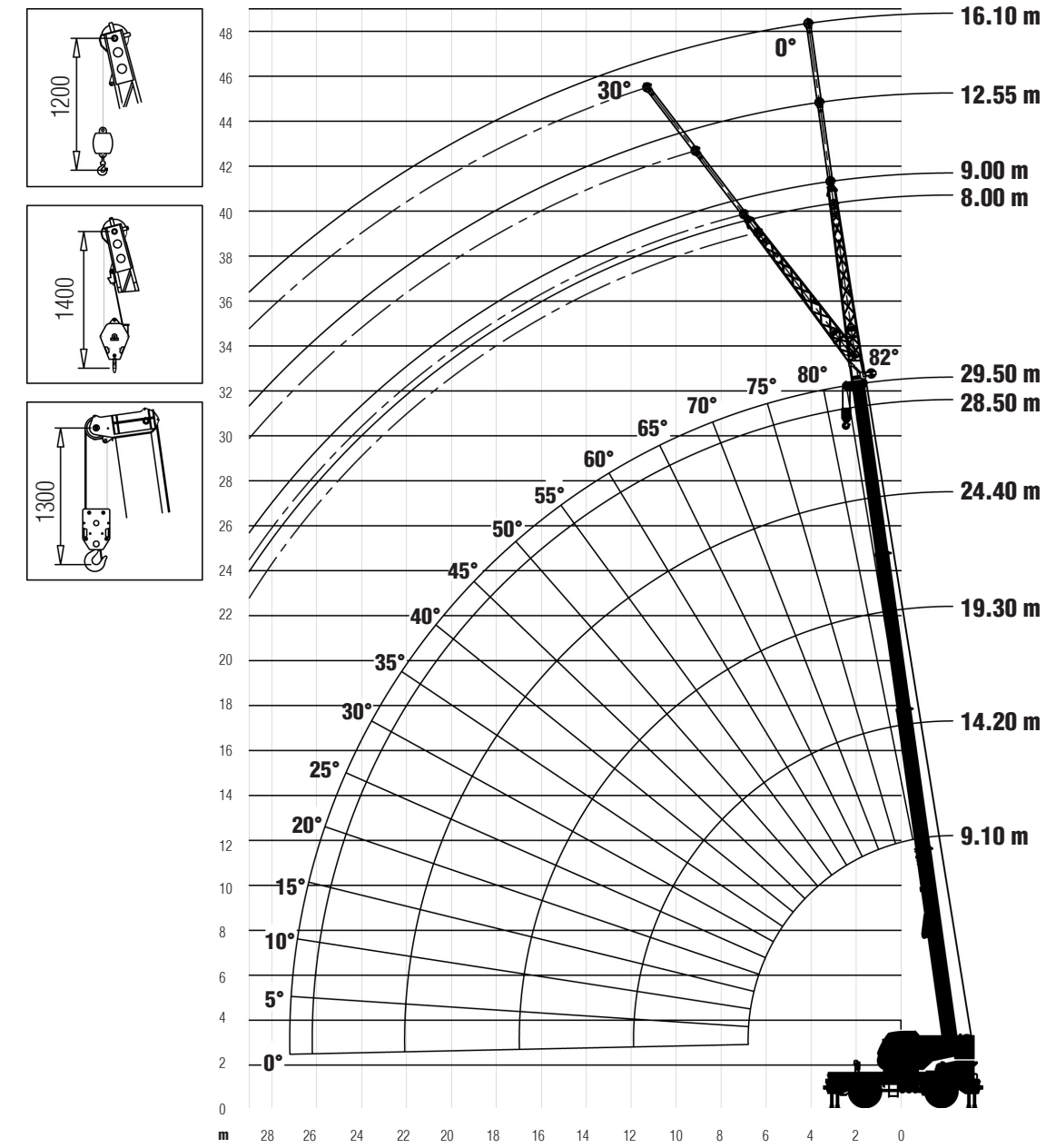

NOTE SULLA TABELLA DI PORTATE

- I carichi riportati nella tabella di portata sono a norme CE.
- Le portate sono indicate in tonnellate.
- Il peso dei bozzelli, delle prolungher braccio, delle imbracature e di qualsiasi altra attrezzatura di sollevamento deve essere detratto dalle portate indicate in tabella per ottenere il carico netto sollevabile.
- I raggi di lavoro sono misurati dal centro della ralla di rotazione.
- Per lunghezze di braccio e/o raggi di lavoro non elencati, usare il carico minore corrispondente alla lunghezza di braccio e/o al raggio di lavoro immediatamente successivi.
- Le portate su stabilizzatori sono valide solo se tutte le travi degli stabilizzatori sono completamente estese e la gru, accuratamente livellata, appoggia su una superficie di supporto solida.
- Le portate su pneumatici sono valide a condizione che i pneumatici siano gonfiati alla pressione prescritta e che la gru operi su un terreno piano, solido ed orizzontale:
 - per le portate statiche su 360° l'oscillazione dell'assale posteriore deve essere bloccata.
 - per le portate frontali in traslazione il fermo di blocco della rotazione deve essere inserito e la marcia con il carico sospeso deve essere eseguita con il carico leggermente sollevato da terra, prossimo alla gru, evitando oscillazioni del carico

NOTES TO LOAD CHARTS

- The tabulated lifting capacities comply with the CE standards.
- Lifting capacities are given in metric tons.
- The weight of the hookblocks, boom extensions, sling and all auxiliary lifting devices must be deducted from the lifting capacities to obtain the net load to be lifted.
- Working radii are measured from the slewing centreline.
- For boom lengths and/or radii not listed use the smallest load given for the next longer boom length and/or radius.
- The capacities on outriggers are valid only if all outrigger beams are fully extended and the crane accurately levelled on a firm supporting surface.
- The capacities on tyres are valid only if the tyres are inflated to the recommended pressure and the crane works on a flat, solid and horizontal surface:
 - for 360° static capacities the rear axle oscillation must be locked.
 - for over front travelling capacities the swing lock pin must be fully engaged and the travel with suspended load should be carried out with the load little raised from the ground, close to the crane and avoiding load oscillations

PORTATE PROLUNGA - LIFTING CAPACITIES BOOM EXTENSION - CAPACITES DE LEVAGE FLECHETTE TRAGLASTEN KLAPPSPITZE - CAPACIDADES DE CARGA PLUMIN

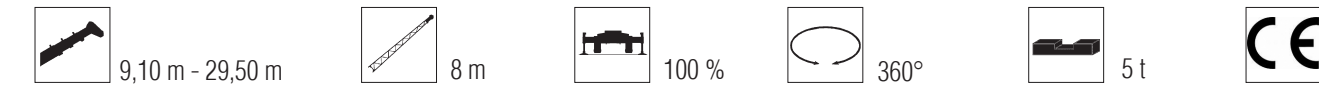

m	9,10 m		24,40 m		29,50 m		m
	8 m		8 m		8 m		
	0°	30°	0°	30°	0°	30°	
3,0	3,1						3,0
3,5	3,0						3,5
4,0	3,0		3,4				4,0
4,5	2,7	1,2	3,3				4,5
5,0	2,4	1,2	3,2		3,5		5,0
6,0	2,3	1,0	3,2		3,4		6,0
7,0	2,0	1,0	3,1		3,3		7,0
8,0	1,6	1,0	3,0	1,2	3,2		8,0
9,0	1,3	0,9	3,0	1,1	3,1	1,2	9,0
10,0	1,2	0,9	2,8	1,1	3,0	1,2	10,0
12,0	0,9	0,8	2,5	1,0	2,8	1,1	12,0
14,0	0,7	0,7	2,3	1,0	2,6	1,0	14,0
16,0			1,9	0,9	2,4	1,0	16,0
18,0			1,5	0,9	2,1	0,9	18,0
20,0			1,2	0,8	1,7	0,9	20,0
22,0			1,0	0,8	1,4	0,8	22,0
24,0				0,7	1,2	0,8	24,0
26,0				0,6	0,9	0,7	26,0
28,0					0,7	0,6	28,0
29,0					0,6	0,5	29,0



m	9,10 m				24,40 m				29,50 m				m	
	9 m		12,55 m		16,10 m		9 m		12,55 m		16,10 m			
	0°	30°	0°	30°	0°	30°	0°	30°	0°	30°	0°	30°		
3,0	1,8		1,5		1,3			2,0					3,0	
3,5	1,6		1,4		1,2			2,0				2,0	3,5	
4,0	1,4		1,3		1,0		2,9	1,9		1,5		2,0	4,0	
4,5	1,2		1,2	1,2	0,9		2,6	1,8		1,5		2,0	4,5	
5,0	1,1	1,2	1,0	1,2	0,8		2,3	1,6		1,5		2,9	5,0	
6,0	0,9	1,0	0,9	1,2	0,7		2,0	1,4		1,3		2,7	6,0	
7,0	0,8	0,7	0,7	1,0	0,6	0,7	1,8	1,3		1,1		2,3	7,0	
8,0	0,7	0,7	0,7	0,9	0,5	0,7	1,6	1,5	1,1	1,2	1,0	2,0	8,0	
9,0	0,6	0,6	0,6	0,8	0,4	0,7	1,4	1,3	0,9	1,2	0,9	1,8	9,0	
10,0	0,5	0,5	0,6	0,6	0,3	0,6	1,1	1,0	0,8	1,1	0,8	1,6	10,0	
12,0	0,2	0,4	0,5	0,3	0,2	0,5	0,9	0,8	0,7	1,3	1,0	1,0	1,1	12,0
14,0	0,2	0,3	0,4	0,2	0,2	0,4	0,7	0,6	0,6	0,7	0,6	0,6	1,1	14,0
16,0	0,2	0,2	0,3	0,2		0,3	0,5	0,4	0,5	0,6	0,5	0,5	0,9	16,0
18,0	0,2		0,2		0,2			0,4	0,5	0,5	0,7	0,5	0,6	18,0
20,0			0,2						0,4	0,5	0,5	0,5	0,4	20,0
22,0										0,4	0,4	0,4	0,4	22,0
23,0												0,4	0,4	23,0

DATI TECNICI - SPECIFICATIONS - CARACTERISTIQUES - TECHNISCHE DATEN - DATOS TECNICOS

Peso sugli assali Axle loads Poids d'essieux Achslasten Carga por eje	1	2	Peso totale Total weight Poids total Gesamtgewicht Peso total			
			t	12	15,7	27,7

Km/h	4x4	1	2	3	R1	R2	R3	70%
		3	5,5	16	3	5,5	16	
Km/h	4x2	6	12	37	6	12	37	17%
16,00 x 25								

Funzioni Mechanisms Mécanismes Antriebe Mecanismos	Progressivamente variabile Infinitamente variabile Progressivement variable Stufenlos Infinitamente variable	Diametro / Lunghezza fune Rope diameter / Rope length Diamètre / longueur du câble Seil ø / Seillänge Diámetro cable / longitud cable	Tiro max. ammissibile Max.permissible line pull Effort max. admis sur brin Max. zulässiger Seilzug Carga max. por reenvío
1	0 - 129 m/min	15 mm x 155 m	39,2 kN
2	0 - 62 m/min	15 mm x 120 m	39,2 kN
360°	0 - 3,3 min ⁻¹		
	-3° - +82°	circa 40 s - approx 40 s-env. 40 s - ca 40 s -aprox. 40 s	
	9,10 m - 29,5 m	circa 70 s - approx 70 s-env. 70 s - ca 70 s - aprox. 70 s	

Portata Lifting capacity Force de levage Traglast Capacidad de carga	N° di carucole No of sheaves Nbr de poulies N° der Rollen No de reenvíos	N° di taglie No of lines Nbr de brins Strangzahl No de reenvíos	Peso Weight Poids Gewicht Peso
35 t	5	10	400 kg
12 t	1	3	180 kg
5 t	-	1	100 kg

Con riserva di modifiche senza preavviso / Subject to modification without notice / Änderungen vorbehalten / Sous réserve de modification sous préavis / Salvo modificaciones sin notificación previa.

Simboli - Symbols - Symboles - Symbolen - Símbolos

Braccio telescopico Telescopic boom Fleche télescopique Teleskopausleger Pluma telescópica	Prolunga braccio Boom extension Rallonge de fleche Klappspitze Extensión de pluma	Stabilizzatori Outriggers Calage Abstützungen Estabilizadores	Pneumatici Tyres Pneumatiques Bereitung Neumáticos	Rotazione Slewing Orientation Drehwerk Giro
Contrappeso Counterweight Contrepoids Gegenwicht Contrapeso	Raggio Radius Portée Ausladung Radio	Marcia Gear Rapport Gang Marcha	Gamma lenta Low range Gamme basse Gelände Gamma lenta	Gamma veloce High range Gamme haute Strasse Gamma alta
Argano principale Main hoist Treuil principal Hauptwerk Cabrestante principal	Argano ausiliario Auxiliary hoist Treuil auxiliaire Hilfswerk Cabrestante auxiliar	Stilo braccio Boom telescoping Télescopage de fleche Teleskopieren Telescopaje de pluma	Elevazione braccio Boom elevation Relevage de fleche Wipswerk Elevación de pluma	Bozzello Hookblock Crochet moufle Hachenflasche Gancio